

OL-X8KXXXXX-R

Extremely Low Power Consumption, Fast Warm-up, SC-cut, Precision, Very Low Phase Noise OCXO in DIP14 Compatible Through Hole Package

Features

- SC-cut crystal
- Extremely Low Power Consumption (125 mW)
- Fast Warm-up Time (to 30 s)
- High Stability (up to $\pm 1 \times 10^{-8}$)
- Low Aging (5×10^{-10} /day, 5×10^{-8} /year)
- Very Low Phase Noise(-165 dBc/Hz, TYP, floor)
- Sine Wave or HCMOS/TTL output
- 8 MHz to 250 MHz Frequencies Available
- RoHS Compliant

Applications

- Telecommunication Systems
- Data Communications
- GPS
- Battery Powered Systems and Equipment

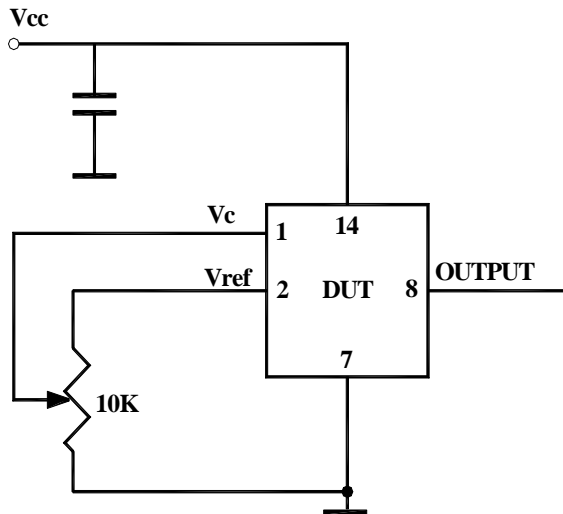
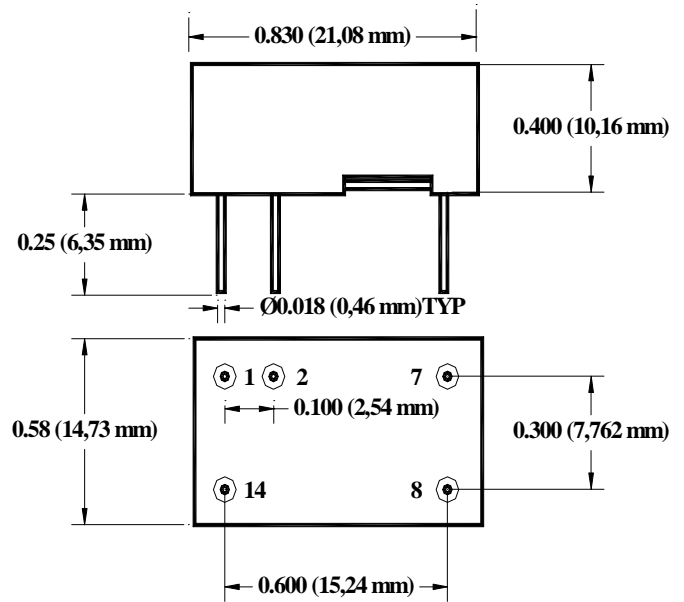

OL-X8KXXXXX-R Series

Parameter	Symb	Condition	Min	Typ	Max	Unit	Note
-----------	------	-----------	-----	-----	-----	------	------

Absolute Maximum Ratings

Input Break Down Voltage	Vcc		-0.5		5.5	V	
Storage temper.	Ts		-40		85	°C	
Control Voltage	Vc		-1		7	V	

Electrical (4)

Frequency	F		8	10.000	250	MHz	1*	
Frequency stability	$\Delta F/F$	vs. Temp.		± 50		ppb	See chart below	
		vs. Supply		1	2	ppb/V		
Aging		per day per year		5E-10 1E-7			after 30 days 5E-8 available2*	
Allan Deviation		.1s to 10s		1E-11				
SSB Phase Noise		1Hz		-90		dBc/Hz	3*	
		10 Hz		-125				
		100 Hz		-145				
		1 KHz		-155				
		10 KHz		-165				
Retrace		After 30 minutes			± 10	ppb		
G-sensitivity		worst direction			± 1.0	ppb/G		
Input Voltage	Vcc		4.75 3.15	5.0 3.3	5.25 3.45	V	See chart below to specify	
Power consumption	P	steady state, 25°C steady state, -30°C start-up @ -30°C		0.125 0.35 0.5	0.2 1.0	W	Standard Operating Temperature, for Op Temp. 85 °C ad 20%	
Spectral Purity		Subharmonics Spurious Harmonics/Sine			-40 -80 -35	dBc	At Higher Frequencies	
Load		10KOhm//15pF (HCMOS/TTL), 50 Ohm (Sinewave)						
Warm-up time	τ	to 0.1ppm accuracy		30	45	s		
Output Waveform		3.3V HCMOS/TTL compatible or Sinewave (+7± 3) dBm						
Control voltage	Vc		0		Vref	V		
Pull range		from nominal F	± 0.5	± 1		ppm		
Deviation slope		Monotonic, posit		0.4		ppm/V		
Stability	Vc0	@25°C, Fnom.	Vref/2-1	Vref/2	Vref/2+1	V		

All parameters for 10 MHz

Notes:

1* Higher frequencies can be achieved either by using higher frequency crystals or by low noise analog harmonic multiplication. Both methods have advantages and drawbacks. If lowest possible phase noise on the noise floor is most important – high frequency crystal will be used. If phase noise close to the carrier and aging are more important – multiplication will be used. Please consult factory for your specific requirement.

2* Aging rate is usually proportional to the operating frequency, unless higher frequency is achieved by multiplication. Keep it in mind while specifying aging.

3* Phase noise deteriorates with frequencies going higher. If analog multiplication is used to achieve higher frequency the phase noise roughly follows the formula of additional 20LogN, where N is a multiplication factor across entire frequency offset range. If higher frequency is achieved by using higher frequency crystal phase noise close to the carrier deteriorates due to the lower Q of the crystal and is usually worse, compared to multiplied solution. On the noise floor, however it remains more or less the same. This design usually starts utilizing multiplication techniques in the range of 25 MHz to 35 MHz..

4. All parameters, unless otherwise specified, are at nominal conditions, ie: T=25°C, Nominal Vcc & Nominal Load.

5. Not designed for reflow.



OL-X8KXXXXX-R Series

Rev. P

Environmental and Mechanical

Operating temp. range	-30°C to 70°C Standard, Other options – see chart below
Mechanical Shock	Per MIL-STD-202, 30G, 11ms
Vibration	Per MIL-STD-202, 5G to 2000 Hz
Soldering Conditions (5)	260°C for 10s Max leads only

Electrical Connections

Pin Out	Pin #1-Vc ; Pin#2 – Vref (optional); ; Pin #7- GND; Pin #8- Output ; Pin #14 – Vcc
----------------	--

Creating a Part Number

OL - X 8K X XX X X - R - FREQ

Package Code

OL 5 pin (DIP 14) 21x14.7mm pkg

Environmental

Code	Specification
R	RoHS compliant, not designed for reflow

Supply Voltage

Code	Specification
0	5V ± 5%
A	3.3V ± 5%

V Reference option

Code	Specification
R	4.0 V/ 2.8V w. 5V/3.3V Vcc
0	No pin

Output

Code	Specification
T	TTL
S	Sinewave

Temperature Stability

Code	Specification
17	1x10 ⁻⁷
58	5x10 ⁻⁸
28	2x10 ⁻⁸
18	1x10 ⁻⁸
YZ	Yx10 ^{-Z}

Temperature Range

Code	Specification
A	0°C to 50°C
B	0°C to 70°C
C	-20°C to 70°C
D	-40°C to 85°C
E	-10°C to 60°C
F	-40°C to 80°C
G	-30°C to 70°C
9	Customer Specific

Not all combinations are available. Consult Factory.

